

## Quick Drive Erase

The Quick Drive Erase allows for the partial data erasure of the drive so that a drive that passed all functional and media tests is made ready for the reinstallation of the operating system and applications. The time required to perform this function varies depending on the hard drive. Newer Western Digital hard drives include features which allow this process to be completed in less than one minute. Once started, this function cannot be aborted. Older Western Digital and other make hard drives will complete this function within approximately five minutes. With these drives, you will be able to abort this function or restart it if desired. This operation is data destructive. However, if you have not started this function, you can abort and return to the main menu without any data loss.

**Caution:** Do not pull the power cord to abort this function, as this will cause media errors and will require the Full Drive Test or Quick Drive Erase to correct the errors.

## Utility Menu

The Utility Menu provides access to Test Data Ops, Time, and Comm Settings.

## Test Data Ops

This is a sub-menu that is used to manage the database and upload the saved data to a PC with the following choices:

- **Upload Test Data:** Selecting this option will cause the WD Quick Tester to upload the database to a computing device attached to the other end of the serial cable. This is a 'blind' transfer (no hand shaking is required for the transfer). Once started, all used records are sent.
- **Delete Data:** There are two options in this selection. The first deletes the most recent test record which can be useful if you abort an operation or for any other reason you need to delete the record. The second option causes the entire database to be deleted.
- **DB Memory Usage:** This displays the number of used records indicated by the message "Recs: xxx/100" where xxx is a number between 0 and 100. When the database is full, the tester will overwrite the earliest record in a circular fashion.
- **Done:** Return to the previous menu.

## Time

The time function allows setting of the hour, minute, second, and month/day/year (last 2 digits). The tester will not allow resetting of the date/time value if there is test data in the database. To edit this function, enter the Time option and press **Select/Yes** to edit the Time or Date. Press **Next/No** to exit the time set function. Under the Time option, the buttons operate as follows:

- **Select/Yes** allows you to select the value (Hour 00 thru 23, Minute 00 thru 59, Cancel, etc.). Pressing this button will increment the count by 1 and continue until it reaches the highest number set for that value then rolls back to 00.
- **Next/No** allows you to select from the various settings (Hours, Minutes, Seconds, etc.).

## Comm Settings

Use this option to set and view the **Upload Baud Rate**. Values supported are 1,200 (default), 9,600, and 19,200 baud. The **View Cur Baud** will display the current baud

rate selected. Use the **Set Baud Rate** option to scroll through the three supported baud rates, pressing **Select/Yes** to set the value or **Next/No** to move to the next choice. As with all menus on this tester, a choice of **Done** is given allowing you to return to the previous menu.

## WD Quick Tester Database

The database is a flat file structure used to store test data from each drive tested, up to 100 test records. It provides the user a simple way to store information and upload the data to a computing device for processing. The tester does not allow for viewing of data once stored.

## Power Supply

The WD Quick Tester uses a 3V coin-size Lithium battery to power the SRAM during times of inactivity. Battery life is between 1.5 to 2.0 years. Without a battery, the WD Quick Tester can still function, but the data and time will not be accurate, and any test data stored in the internal database will be lost when power is removed.

To replace the battery, download the step-by-step instructions from our Web site at [www.westerndigital.com/support](http://www.westerndigital.com/support).

**IMPORTANT:** Western Digital does not warrant or represent in any way that the WD Quick Tester will function with all make/model EIDE hard drives or identify all faulty drives under test.

The WD Quick Tester may not identify and/or fail drives that function intermittently. Such drives may be able to function but with some difficulty and may only occasionally report an error or failure when tested. The frequency of intermittent failures can change by varying the test conditions, making an actual failure of the drive difficult to identify.

Western Digital is a registered trademark, and WD and the WD logo are trademarks of Western Digital Technologies, Inc. Other marks may be mentioned herein that belong to other companies.

©2004 by Western Digital Technologies, Inc. All rights reserved.

### For service and literature:

support.wdc.com  
www.westerndigital.com  
800.ASK.4WDC North America  
949.672.7199 Spanish  
+800.6008.6008 Asia Pacific  
+31.20.4467651 EMEA

2679-001031-A01 11/04

Western Digital  
20511 Lake Forest Drive  
Lake Forest, CA 92630



# WD Quick Tester



## Quick Reference

### Introduction

The Western Digital Quick Tester is a universal EIDE hard drive tester that is simple to use and requires no prior hard drive knowledge to operate. It was designed to work on all EIDE drives that support the Logical Block Addressing (LBA) mode of operation. To operate, attach the drive to the tester via the included 40-pin EIDE cable, apply power to both tester and drive, and follow the directions as displayed on the Liquid Crystal Display (LCD). A computer system is not required.

### Western Digital Quick Tester Kit Contents

- WD Quick Tester
- 4-conductor power supply "Y" cable
- 40-pin EIDE cable
- WD Quick Tester Quick Reference

### Specifications

- Standard voltage level RS232 interface
- Thermal resettable power line fuse
- Environmental: from 5° to 45° C, non-condensing
- Power requirements: 12 V @ 300 ma; 12 VDC ±10%; ripple and noise 250 mV P-to-P provided by the 4-pin Molex connector used to power the hard drive

### Features at-a-Glance

- Stand-alone tester, a PC is not required for test operation
- Designed to test all hard drives that support LBA mode with enhanced test algorithms for Western Digital drives
- Easy-to-use with simple Pass/Fail results
- Two-button operation with prompted user messages on a 16-character by 2-line LCD
- Drive testing using internal drive S.M.A.R.T.™ features if supported
- Two test options: Quick Drive Test and Full Drive Test (full media scan) with repair functionality
- Two erase functions: Quick Erase and Full Erase operation
- Logging of up to 100 test records in battery backed up SRAM
- Support of an RS232 serial data output of the tester database

### To Start Using the WD Quick Tester Now

1. Verify that the drive jumpers are set for either **Single** or **Cable Select** operations.
2. Attach the tester to the drive using the provided 40-pin EIDE cable.
3. Attach both tester and drive to a power source and apply power.
4. Follow the user messages as displayed on the LCD screen. If testing a non Western Digital drive, refer to the manufacturer's instructions for jumper settings.

**Caution:** Though the Quick/Full Drive Tests are not data destructive, data within all bad sectors will be overwritten. Make sure to back up your data.

## Preparing a Drive for Testing

The following steps will help you ensure proper usage of the WD Quick Tester.

1. **Check jumper settings:** Jumper settings determine the number of devices on a cable in a computer system. The WD Quick Tester supports one hard drive attached at any one time and only certain jumper settings. For Western Digital hard drives, refer to the Jumper Settings section to make sure that the drive attached is jumpered correctly. For non Western Digital hard drives, refer to the manufacturer's documentation.
2. **Check the cable connection:** The WD Quick Tester is supplied with an EIDE cable. Verify that the cable is in good working condition and that pin 1 on both hard drive and tester are aligned. Of the 40 pins on an EIDE connector, pin 1 is designated in red. Most EIDE cables are keyed to fit the connector only one way.

**IMPORTANT:** The EIDE cable must remain in proper working condition to ensure accurate test results.

3. **Check power:** The WD Quick Tester uses a standard 12 V, 4-pin connector on a PC power supply. Verify that the connector you are using is in proper working condition. This connector is also keyed and cannot be reversed but will fit either the hard drive or tester. If the power connector is not attached, the WD Quick Tester may display invalid messages.

## Jumper Settings

For the hard drive to be detected by the WD Quick Tester, the drive must be jumpered according to the manufacturer's instructions. Verify that the jumper settings on the hard drive are supported by the WD Quick Tester. For Western Digital hard drives, refer to the following illustration and setting definitions. For non Western Digital hard drives, refer to the manufacturer's documentation.

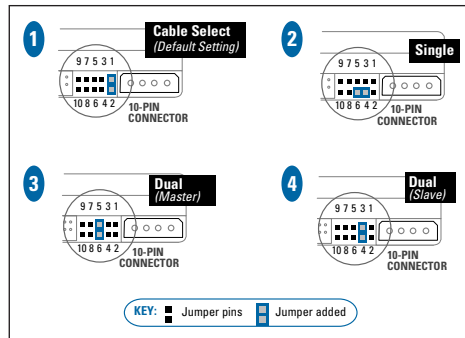

- **Cable Select (CSEL/CS):** Jumper settings remain the same on all hard drives in a system (both single- and multi-drives setups). This protocol requires a special CSEL cable, and the host system must support CSEL. The WD Quick Tester supports this setting.
- **Single:** Indicates the only drive on the cable. Three distinct configurations on Western Digital hard drives are a) pins 3 and 5 for older models, b) pins 4 and 6 for current 10-pin drives, and c) the simplest, for late model drives, all jumpers removed. The WD Quick Tester supports all three configurations of the Single setting.

- **Master:** Designates the drive as the boot device or first device detected on the cable and that a Slave device is present. The WD Quick Tester does not support the Master setting on Western Digital hard drives because these drives have unique configurations for Master and Single. However, the Master setting is supported on other manufacturer hard drives that share the same configuration for Master and Single.
- **Slave:** Designates the drive for use as additional storage and that another device (a Master or boot drive) is on the cable. The WD Quick Tester does not support this setting.

## LEDs

The WD Quick Tester features two LED indicators for user notification. When lit, either or both LEDs denote a particular status.

LED	Indicates
Red	Failure
Green	Requested task completed successfully
Red and Green	Requires user action

## Main Menu

Press the **Next/No** button and continue until the function you wish to perform is displayed. Execute the choice by pressing the **Select/Yes** button.

## Full Drive Test

Highly recommended for all test procedures, the Full Drive Test provides the most extensive testing of the two test functions. Test time for the Full Drive Test will vary depending on the capacity of the drive under test. New generation drives will test at greater than 1 GB per minute while old generation drives may test at less than 10 MB per minute. Test progress is displayed on the second line of the tester LCD. If errors are detected during this operation, the WD Quick Tester will correct the bad sector.

If the drive passes the testing, it is spun down, and the drive information and test data are stored in the tester database. The WD Quick Tester will report that the test is completed and that the drive passed, indicated by both a message on the display and a lit Green LED. **DO NOT** return a drive for repair if it passed the test.

If the drive fails at any point in the testing, the WD Quick Tester attempts to spin down the drive and notifies the user. If the drive failed for user-induced handling damage, **DO NOT** return the drive for warranty repair. If the drive failed for non-customer handling related issues, the WD Quick Tester will report the failure. In both failure cases, the Red LED is lit. The drive information and test data are stored in the tester database.

At any time during the Full Drive Test, you can abort the operation by pressing either button. The test is then stopped, and you are given the choice to **Abort** or **Return** to the test. If you abort, you will not know if the drive is bad.

## Quick Drive Test

The Quick Drive Test is identical to the Full Drive Test except the full media scan is not performed unless an error is detected during testing. The Quick Drive Test may not identify all media related errors but can be used to test basic functionality of a drive. If you suspect media issues, use the Full Drive Test function. If a media-related failure is detected, the WD Quick Tester will report the failure and give the choice to

continue or abort the operation. If further testing is required, do not use the drive until such further testing is performed.

## Drive Failure Notification

If the drive under test is found to be unrecoverable and is failed, the following information will be presented to the user:

##Drive FAIL##. Press Next.

After pressing the **Next/No** button, the Error Code (EC), Main Test function (Mt), and Sub Test (St) function are displayed.

EC:xxx Mt:y St:z. Press Next.

Record this data for future reference. You can download a list of error code definitions from our Web site at [www.westerndigital.com/support](http://www.westerndigital.com/support).

The WD Quick Tester has the ability to detect if the failing drive is a Western Digital model that supports proprietary features. These features can determine if the failure was caused by customer handling. In this case, you will be notified that the drive is not covered under warranty. **DO NOT** return the drive.

Test results are recorded to the drive's logging sector (WD only) with details of the test, assuming the drive is functional enough to support the logging function. Results are also stored in the tester database.

## Drive Pass Notification

As with the fail notification, the WD Quick Tester displays a **Pass** message when testing or erasing has completed successfully. The operator is also required to press the **Next/No** button to acknowledge the successful test completion.

DRIVE PASSED. \*\* Press Next. \*\*

Test results are recorded to the drive's Logging sector with details of the test. Results are also stored in the tester database.

## Full Drive Erase

The Full Erase Function allows for the complete data erasure of the hard drive by writing zeroes to all sectors. Normally the Quick Erase function is sufficient for the successful reinstallation of the operating system on a functional drive. However in some instances, a Full Erase may be desired. Newer Western Digital hard drives incorporate features which allow this process to be completed much quicker than older Western Digital or other make hard drives. Erase speed will vary depending on drive feature:

WD Write = 2 GB per minute  
PIO Write = 3.5 MB per minute

With Western Digital drives that support the WD Write feature, once started, this function cannot be aborted. Using other manufacturer drives, this operation can be aborted and then restarted as desired. For other manufacturer hard drives and WD hard drives that do not support the WD Write function, this function may take several hours to complete.

**Caution:** Do not pull the power cord to abort this function, as this will cause media errors and will require the Full Drive Test or Full Drive Erase to correct the errors.